



**i.Mak**<sup>®</sup>  
REDÜKTÖR & VARYATÖR A.Ş.

## ***Sac Şekil Verme Redüktörü***

Roll Form Gear Units  
***Réducteurs Pour Profileuses***

**D00**

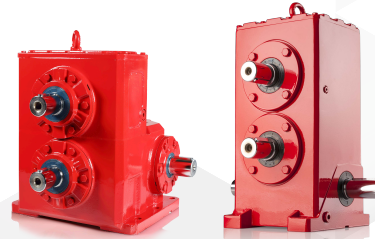

SERIES

ADK  
ADS

2013  
TR | EN | FR

Gearboxes and Drives / Moto Réducteurs



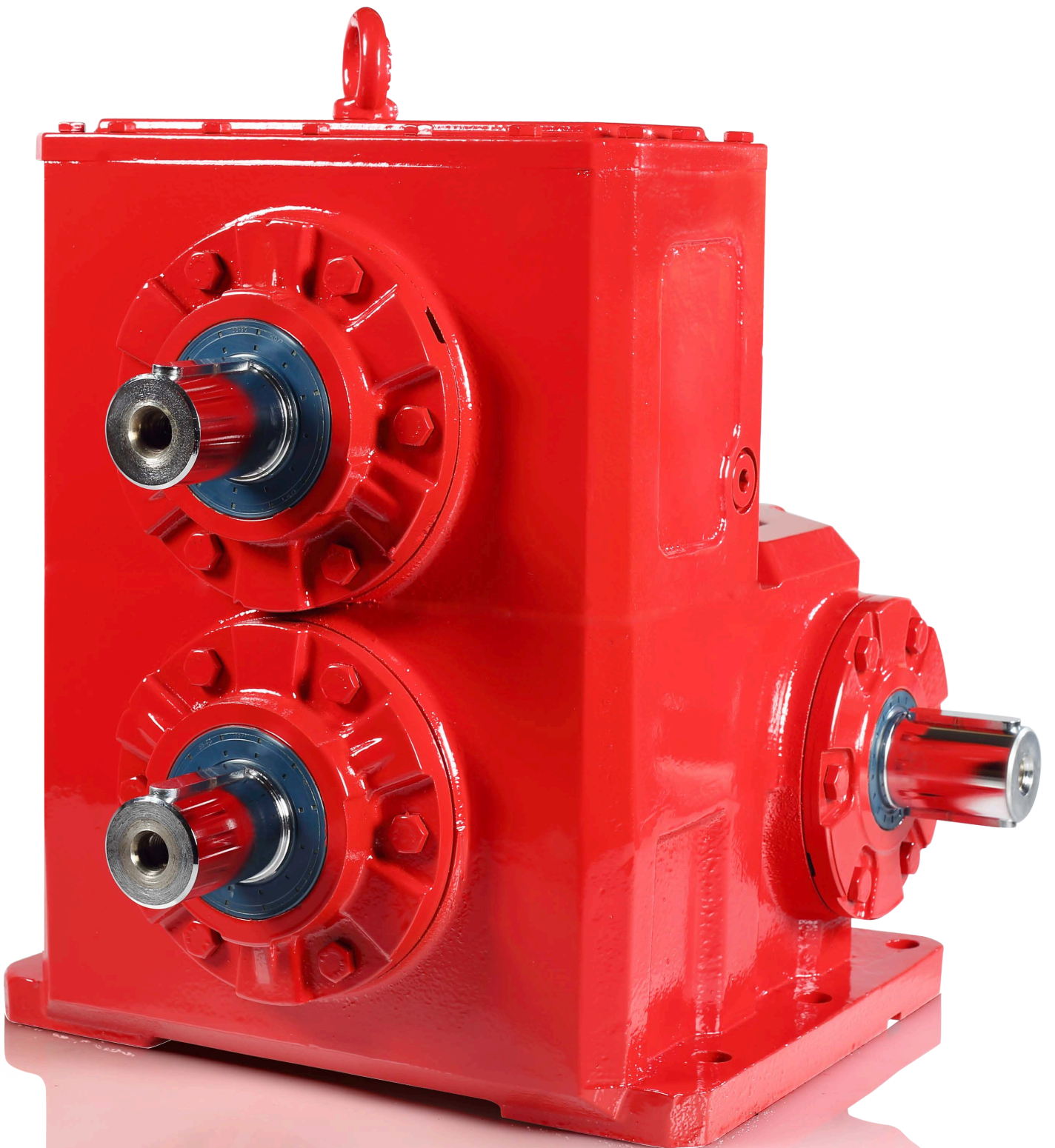

<b>ADK Serisi Redüktörlerin Genel Özellikleri</b> Descriptions and Specifications of the Serie ADK / <i>Descriptions et specifications de la serie ADK</i>	<b>1-3</b>
<b>Redüktör Bağlantı Varyasyonları</b> Mounting Options and Variations / <i>Options de montage et d'accouplement</i>	<b>4</b>
<b>Redüktör Komponent Varyasyonları</b> Gearboxes Components Variations / <i>Options et variations</i>	<b>5</b>
<b>Servis Faktörü</b> Service Factor / <i>Service facteur</i>	<b>6</b>
<b>Redüktör Yükleme Karakteristikleri</b> Load Characteristics of Gearboxes / <i>Types de machines et applications</i>	<b>7-10</b>
<b>Motor İşletme Değerleri</b> Motor Performance / <i>Performance Moteurs</i>	<b>11-12</b>
<b>Yağ Tablosu</b> Lubricant Table / <i>Huiles et lubrifiants</i>	<b>13</b>
<b>Redüktörlerin Kontrol ve Bakımları</b> Control and Mintenance of Gearboxes / <i>Contrôle et maintenance des réducteurs</i>	<b>14</b>
<b>Sertifikalarımız</b> Certifications / <i>Certificats</i>	<b>15</b>
<b>ADK Serisi Redüktörler Ölçü Sayfaları</b> Dimensions Pages / <i>Dimensions</i>	<b>16-18</b>
<b>ADK Serisi Yedek Parça Şeması ve Listesi</b> General Parts List / <i>Liste des pièces détachées</i>	<b>20-22</b>
<b>ADS Serisi Redüktörlerin Genel Özellikleri</b> Descriptions and Specifications of the Serie ADS / <i>Descriptions et specifications de la serie ADS</i>	<b>24</b>
<b>ADK Serisi Redüktörler Ölçü Sayfaları</b> Dimensions Pages / <i>Dimensions</i>	<b>26-29</b>
<b>ADK Serisi Yedek Parça Şeması ve Listesi</b> General Parts List / <i>Liste des pièces détachées</i>	<b>30-32</b>

## Genel Bilgiler

---

General Information  
*Informations g n rales*

# ADK

SERİSİ / SERIES / SÉRIES

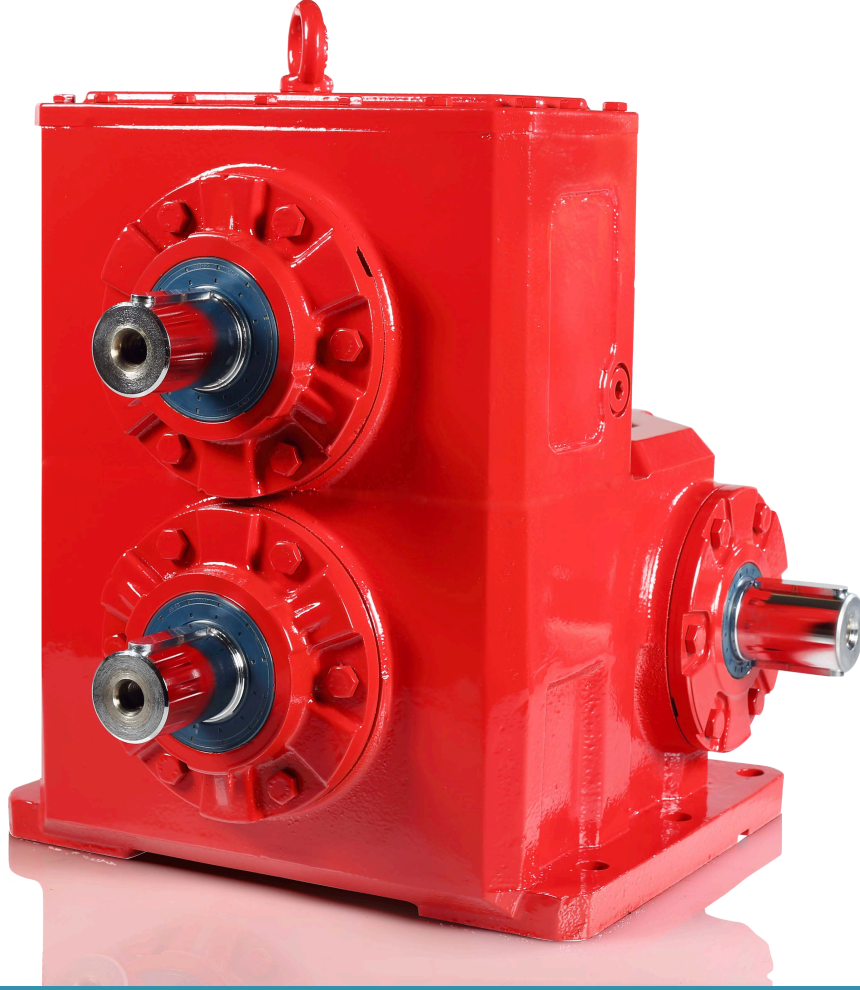

- Monoblok döküm gövdeli
- 2400 – 3400 Nm moment aralığı
- 1 – 1,40 Tahvil aralığı

- Cast iron monobloc housing
- Torque range from 2400 to 3400 Nm
- Ratio range from 1 to 1,40

- *Carter monobloc en fonte*
- *Couple allant de 2400 à 3400 Nm*
- *Rapport de réduction compris entre 1 et 1,40*

### **ADK / ADS serisi redüktörlerin genel özellikleri**

Boru, kablo kanalları, otomotiv sektörü ve birçok profillerin oluşturulmasında, roll-form hatlarına ve bunların tahriklerinde kullanılan redüktörlere ihtiyaç duyulmaktadır. Bu saca şekil verme hatları, yapılacak üretime göre birkaç istasyondan oluşabilir. Bu istasyonlarda yerine göre çift çıkış tahrik veya tek çıkış milinden tahrik olabilir. Ayrıca üst ve alt mil arasında devir farkı olabilir (Üst mil devri genelde daha yavaş istenir). Bu gibi ihtiyaçlar için aşağıdaki ürünlerimizi kullanabilirsiniz.

### **Descriptions and specifications of the ADK / ADS series.**

Designed for the roll form industry the configuration and features of the new ADK/ADS makes it the best solutions for your roll form machines. The new ADK is configured with a double input shaft configuration allowing the display of the gearbox on a single line, this new configuration also allow to drive the whole group of gearboxes with a single or twin motor. I-MAK also updated the housing design to reduce the distance between the gearboxes, allowing you to reduce the length of your line. The output shaft distance can be customized to adapt to the design and configuration of your machine. Please do not hesitate to contact our team of experts for more information on this unique solution.!

### **Descriptions et spécifications de la séries ADK / ADS.**

Découvrez notre nouvelle solution pour la production de profilés en acier et aluminium. La configuration spéciale des réducteurs ADK/ADS permet de réduire les coûts d'investissements initiaux d'une ligne de production tout en augmentant la capacité de votre profileuse. Les nouveaux réducteurs ADK et ADS se composent de deux arbres d'entrées synchronisés et alignés sur le même axe pour permettre le montage linéaire des réducteurs et l'alimentation avec un moteur unique. I-MAK offre aussi une flexibilité supplémentaire avec la possibilité d'adapter la distance entre les deux arbres de sortie en fonction de votre projet. N'hésitez pas à contacter nos équipes d'experts pour plus d'informations !

## Çıkış mili / Output shaft / Arbre de sortie

Kod / Code	Varyasyon	Options	Options
111	Özel mil ölçüsü	Special shaft dimensions	Dimensions de l'arbre spécial
112	Özel mil malzemesi	Special shaft materials	Matériel de l'arbre spécial
113	Sertleştirilmiş mil	Hardened shaft	Axe durci
114	Diş çekilmiş mil	Shaft with screw	Axe à vis
115	Çoklu kama uygulaması	Shaft with multiple key	Arbre à multi clavette

## Giriş mili - pam mili / Input shaft / Arbre d'entrée

Kod / Code	Varyasyon	Options	Options
131	Özel mil ölçüsü	Dimensions of the shaft	Dimensions de l'arbre ( Spécial )
132	Özel mil malzemesi	Material of special shaft	Matériaux de l'arbre ( Spécial )
133	Sertleştirilmiş mil	Hardened steel shaft	Arbre en acier trempé
134	Çoklu kama uygulaması	Hollow shaft with screw	Arbre creux a vis
135	Özel alın mili	Spécial input shaft	Arbre d'entrée spécial
136	Diş çekilmiş mil	Shaft with screw	Arbre de sortie avec vis



## Yağ / Oil / Huiles

Kod / Code	Varyasyon	Options	Options
211	Sentetik yağ VG 220 (SHC 630)	Synthetic oil VG 220 ( SHC 630 )	Huile synthétique VG 220 ( SHC 630 )
212	Gıda uyumlu yağ VG 220 (CIBUS 220)	Food compatible oil VG 220 ( CIBUS 220 )	Huile pour industrie agroalimentaire VG 220 (CIBUS 220)
213	-40C° Uyumlu yağ VG 220 (SHC 630)	Cold resistant oil -40C° VG 220 ( SHC 630 )	Huile base température -40C° VG220 ( SHC 630 )

## Keçe-tapa / Seal-cover / Joint- bouchon

Kod / Code	Varyasyon	Options	Options
221	Özel ölçü keçe	Dimensions of special seal	Dimensions du joint (Spécial)
222	Özel ölçü tapa	Dimensions of special cover	Dimensions du bouchon ( Spécial )
223	Özel marka keçe	Special brand of seal	Marque du joint ( Spécial )
224	Özel marka tapa	Special brand of cover	Marque du bouchon ( Spécial )
225	Viton keçe	Viton seal	Joint en viton
226	Özel tip keçe uygulaması	Special configuration of seal	Configuration spéciale du joint
227	Toz kapağı	Dust cover	Bouchon anti-poussière

## Rulman / Bearing / Roulement

Kod / Code	Varyasyon	Options	Options
231	Güçlendirilmiş çıkış rulmanı	Reinforced output bearing	Roulement renforcé ( Sortie )
232	Güçlendirilmiş giriş rulmanı	Reinforced input bearing	Roulement renforcée ( Entrée )
233	Özel marka rulman	Special brand of bearing	Marque du roulement ( Spécial )
234	Özel ölçü rulman	Special dimensions of bearing	Dimensions du roulement ( Spécial )
235	Mekanik kilit CW*	Backstop bearing ( CW )	Roulement anti-retour ( CW )
236	Mekanik kilit CCW*	Backstop bearing ( CCW )	Roulement anti-retour ( CCW )

\* İRO ve YP serileri için geçerlidir, diğer serilerde motora uygulanmaktadır. / Available in YP and IRO Series, the other series are equipped with backstop bearings at motor side / Disponible pour les séries YP et IRO, les autres séries sont équipés de roulement anti-retour placés sur le moteur.

## Gövde / Housing / Carter

Kod / Code	Varyasyon	Options	Options
241	Özel işlenmiş gövde	Special housing	Carter spéciale
242	Özel malzeme	Special housing materials	Carter avec matériaux spéciaux

## Boya / Paint / Peinture

Kod / Code	Varyasyon	Options	Options
251	Özel renk boya	Special paint color	Couleur spéciale
252	Özel tip boya	Special paint type	Type de peinture spéciale
253	Epoksi boya	Epoxy paint	Peinture epoxy
254	Akrilik boya (dış ortam)	Acrylic paint	Peinture acrylique (Environnement extérieur)
255	Su bazlı boya	Water based paint	Peinture à base d'eau
256	Antikorozif boya	Anti-corrosion paint	Peinture anti-corrosion

## Dişli / Gears / Pignons

Kod / Code	Varyasyon	Options	Options
261*	Özel imalat dişli	Special gear	Pignons spéciaux
262	Katalog dışı tahvil	Gear ratio ( Catalogue )	Rapport de réduction des pignons (Catalogue)

\* 261 kodu, 262 yi kapsamaktadır. / 261 and 262 codes are equivalent / Les codes 261 et 262 sont équivalents

**Servis Faktörü ( $F_s$ )**  
**Servis Faktörü = İşletme**  
**Katsayısı = ( $F_s$ )**

Redüktörlerdeki bu değer, tahrik edeceği makinenin bütün teknik ve karakteristik özelliklerine dayanma süresine bağlıdır. Genel olarak makineler yüklenme bakımından üç tip karakteristik gösterirler.

1. HAFİF YÜK (U)
2. ORTA YÜK (M)
3. AĞIR YÜK (H)

Üç değişik yükleme biçiminde çalışan, üç ayrı makinede üretilen momentler birbirine eşitte olsalar, ağır çalışan makinede daha büyük işletme katsayılı Redüktör kullanılmaktadır.

Günlük çalışma saati ise, çalışan dişli ve transmisyon elemanlarının malzeme yorulmasına maruz kalması bakımından, çalışma saatinin fazla olması halinde zararlı yönde etki eder.

Star-Stop durumuna gelince, her makinenin ilk kalkış esnasında en yüksek yüke maruz kaldığı düşünülürse tehlikeli görülür. Müteakip çalışmalarda bu daha aşağıya düşer.

Kataloğumuzda işletme katsayılarının nasıl kullanıldığının anlaşılması için bir misal ile belirtelim.

Önce tablo-1'den makinenin çalışma sahasına göre karakteristiğini belirleyelim. Makinemiz elektrik motor tahrikli ZİNCİR KOVALI EKSKAVATÖR ise yükleme durumu AĞIR' dır. ( H ) Tablo 2'den makine 24 saat çalışacağına göre minimum işletme katsayısı  $F_s = 2$  bulunur.

**Service Factor ( $F_s$ )**

Value of the service factor of a gearbox depends on all technical and characteristic specifications of a driven machine. Generally machines have three types of loading characteristics:

1. UNIFORM LOAD (U)
2. MODERATE LOAD (M)
3. HEAVY LOAD (H)

Even if the torques required by three different machines operating at three different load specifications are equal.

Gearbox of the machine operating under heavy load conditions should have greater service factor.

Daily working period has effect on gearbox elements due to the materials fatigue of working parts.

It must be taken into account that all machines are subject to the greatest load at the first start, so that the number of starts has also effect on service factor.

This is an example how to use the service factor given in the catalogue.

Load specification of machine should be determined first, from table 1 in our example, the machine is CHAIN BUCKET EXCAVATOR driven by electric motor has HEAVY load specification and daily operation time is 24 hours. So that minimum service factor  $F_s = 2$  is taken from Table 2.

**Service facteur ( $F_s$ )**

La valeur du service facteur d'un motoréducteur dépend des caractéristique de l'application. Ont distingue trois type de charges différentes

1. Charges uniformes (U)
2. Charges modérées (M)
3. Charges élevées (H)

Les spécifications des charges restent les même lorsque trois machines différentes sont soumises à des charges distinctes.

Les réducteurs utilisés dans des applications soumises à de fortes charges doivent obligatoirement avoir des services facteurs élevés.

Le nombre d'heures d'utilisations journalières a une influence directe sur l'usure des pièces et composants du réducteur.

Le réducteur est soumis à une charge maximale lors du démarrage de l'application. Le nombre d'arrêt/rédémarrage est donc à prendre en compte lors de l'analyse du service facteur.

L'exemple çı-dessous explique le processus d'analyse et de calcul du service facteur.

L'application étudiée est un excavateur a godets (Tableau 1) , le réducteur est actionné par un moteur électrique. La charge est "élevée" et la durée de fonctionnement journalière est de 24h. En se basant sur le tableau 2, le service facteur minimum requis est  $F_s = 2$

Ekskavatörler		Excavators		Excavateur	
Zincir kovalı ekskavatörler	H	Chain-Bucket excavators	H	Excavateurs à gaudets	H
Paletli yürüyüşler	H	Travelling gears (Caterpillar)	H	Convoyeur à étage	H
Ray üzerinde yürüyüşler	M	Travelling gears ( Rails )	M	Convoyeur à rails	M
Manevra mekanizmaları	U	Manoeuvring winches	U	Grues à manœuvre	U
Emiş pompaları	M	Pumps	M	Pompes	M
Kovalı çarklar	H	Bucket wheels	H	Roue à gaudets	H
Dönüş mekanizmalar	M	Slewing gears	M	Pignons rotatif	M

İnşaat Makinaları		Building Machines		Machine de Construction	
İnşaat asansörleri	U	Hoists	U	Grues de construction	U
Betoniyerler	M	Concrete mixers	M	Malaxeur à béton	M
Yol inşaat makinaları	M	Road construction machines	M	Machine de construction(routes)	M

Kaldırma ve İletme Tesisleri		Conveyor		Convoyeurs	
Zincirli konveyör	M	Through chain conveyors	M	Convoyeurs à chaines	M
Mafsal bantlı konveyörler	M	Link conveyors	M	Convoyeur à bande souple	M
Lastik bantlı konveyörler (Dökme Yükler)	U	Belt conveyors (Bulk Goods)	U	Convoyeur à bande rigide	U
Lastik bantlı elevatörler	M	Ballast elevators	M	Elevateurs à bande	M
Lastik cepli elevatörler	M	Ballast pocket elevators	M	Elevateur à poche	M
Lastik bantlı konveyörler (Parça Yükler)	M	Belt conveyors (Piece Goods)	M	Convoyeur à bande	M
Askılı konveyörler	U	Chain conveyors	U	Convoyeur à chaines	U
Yük asansörleri	M	Goods lifts	M	Élévateur à chaines	M
Kovalı elevatörler (Toz Malzeme)	U	Bucket elevators (Flour Goods)	U	Élévateur à godets (graviers)	U
Helezon konveyör	M	Screw conveyors	M	Vis d'Archimède	M
Kovalı elevatörler (Parçalı Malzeme)	M	Bucket elevators (Piece Goods)	M	Élevateurs à godets (Roches)	M
Eğik asansörler	H	Inclined hoists	H	Grues inclinées	H
Çelik bantlı konveyörler	M	Steel belt conveyors	M	Convoyeur à bande (Acier)	M
Paletli konveyörler	M	Apron conveyors	M	Convoyeurs à palettes	M

Tahrik Makinası Torque Machine Machines couplées	Günlük Çalışma Müddeti (Saat) Daily Working Period (Hour) Utilisation journalière (Heure)	Makinanın Yükleme Karakteristiği Load Characteristics of Machines Caractéristique des charges		
		Hafif Yük U Uniform Load U Charge uniforme U	Orta Yük M Moderate Load M Charge modérée M	Ağır Yük H Heavy Load H Charge élevée H
<b>Elekt. Motorlu</b> / Elect. Motor / <i>Moteurs élect.</i> <b>Türbin</b> / Turbin / <i>Turbine</i> <b>Hidrolik</b> / Hydraulic / <i>Hydraulique</i>	0.....3	0.8	1	1.5
	3....10	1	1.25	1.75
	10...24	1.25	1.5	2
<b>Pistonlu Makinalar ( 4....6 Silindir</b> Piston Machines ( 4....6 Cylinder ) <i>Machine à pistons ( 4.....6 Cylindres )</i>	0.....3	1	1.25	2
	3....10	1.25	1.5	2
	10...24	1.5	1.75	2
<b>Pistonlu Makinalar ( 1.....2 Silindir)</b> Piston Machines ( 1.....2 Cylinder ) <i>Machine à pistons ( 1.....2 Cylindres )</i>	0.....3	1.25	1.5	2
	3....10	1.5	1.75	2.25
	10...24	1.75	2	2.5

Kimya Endüstrisi		Chemical Industry		Industrie Chimique	
Soğutma tamburları	M	Cooling drums	M	Tambours de refroidissement	M
Karıştırıcılar	M	Mixers	M	Mixeurs	M
Çalkalayıcılar (Hafif Akışkanlar)	U	Agitators ( Liquids )	U	Agitateurs (Liquides)	U
Çalkalayıcılar (Ağır Akışkanlar)	M	Agitators ( Semi Liquids )	M	Agitateurs (Semi liquide)	M
Tambur kurutucuları	M	Drying drums	M	Tambours de séchage	M
Santrifüjler	U	Centrifuges ( Lights )	U	Centrifugeuse (Légère)	U
Santrifüjler	H	Centrifuges ( Heavy )	H	Centrifugeuse (Lourde)	H

Petrol Endüstrisi		Oil Industry		Pétrole et Hydrocarbures	
Boru hattı pompaları	M	Pipeline pumps	M	Pompes à oléoducs	M
Kuyu açma mekanizmaları	H	Rotary drilling equipment	H	Foreuse à cylindres	H

Ventilatör Ve Aspiratörler		Fans		Ventilations	
Pistonlu ventilatörler	M	Rotary piston blowers	M	Souffleurs rotatifs	M
Ventilatör ( Aksiyal ve Radyal )	U	Blowers ( Axial and Radial )	U	Souffleurs ( Axe et radial )	U
Santrifüj (türbinli) körük	H	Centrifugal	H	Centrifugeuse	H

Kauçuk Makinaları		Rubber Machines		Industrie du Caoutchouc	
Ekstruder ve kanderler	H	Extruders and calenders	H	Extrudeuse	H
Yoğurma makinaları	H	Pug mills	H	Malaxeur	H
Karıştırıcılar	M	Mixers	M	Mixeurs	M
Silindirme makinaları	H	Rolling mills	H	Presse	H

Ağaç İşleme Makinaları		Wood Working Machine		Industries Forestières	
Yontma tamburları	H	Backers	H	Presse à bois	H
Planya makinaları	M	Planing machines	M	Aplanisseuses	M
Ağaç işleme tezgahları	U	Wood working machines	U	Découpe de bois	U
Şerit testereler	H	Band saws	H	Scie	H

Yıkama Makinaları		Washing Machines		Laveuses	
Yıkama makinaları	U	Washing machines	U	Machine de lavage	U
Tamburlu kurutucular	M	Tumblers	M	Tambours	M

Tahrik Makinası Torque Machine Machines couplées	Günlük Çalışma Müddeti (Saat) Daily Working Period (Hour) Utilisation journalière (Heure)	Makinanın Yükleme Karakteristiği Load Characteristics of Machines Caractéristique des charges		
		Hafif Yük U Uniform Load U Charge uniforme U	Orta Yük M Moderate Load M Charge modérée M	Ağır Yük H Heavy Load H Charge élevée H
Elekt. Motorlu / Elect. Motor / Moteurs élect. Türbin / Turbin / Turbine Hidrolik / Hydraulic / Hydraulique	0....3	0.8	1	1.5
	3....10	1	1.25	1.75
	10...24	1.25	1.5	2
Pistonlu Makinalar ( 4....6 Silindir Piston Machines ( 4....6 Cylinder ) Machine à pistons ( 4....6 Cylindres )	0....3	1	1.25	2
	3....10	1.25	1.5	2
	10...24	1.5	1.75	2
Pistonlu Makinalar ( 1....2 Silindir Piston Machines ( 1....2 Cylinder ) Machine à pistons ( 1....2 Cylindres )	0....3	1.25	1.5	2
	3....10	1.5	1.75	2.25
	10...24	1.75	2	2.5

Vinç Tesisleri		Cranes		Grues	
Bom kaldırma	H	Derricking jib bomm gear	H	Bras ouvrant	H
Vinç yürüyüşleri	U	Travelling gears	U	Grues(Charriot )	U
Yük kaldırma	H	Hoist gears	H	Grues	H
Dönüş tertibatları	U	Slewing gears	U	Pignons rotatifs	U

Metal İşleme Makinaları		Metal Working Machines		Métallurgie et Acieries	
Planya makineleri	S	Planing machine	S	Aplaniseuses	S
Çekiç tokmak	S	Hammer	S	Marteau	S
Oyma makinesi	S	Engraving machine	S	Graveuses	S
Presler	H	Presses	H	Presses	H
Makaslar ( Giyotin )	M	Shears	M	Découpeuses	M
Sıcak basma presleri	H	Forging presses	H	Presse à forge	H
Takım tezgahları ( Ana Tahrık )	M	Machines tools ( Main Drives )	M	Machine outil ( Axe principal )	M
Takım tezgahları ( Yardımcı Tahrık )	U	Machines tools ( Auxiliarily Drives )	U	Machine outil ( axe secondaire )	U

Gıda Endüstri Makinaları		Food Industry Machines		Industrie Agroalimentaire	
Doldurma makinaları ( Şişe, Kavanoz vs.)	U	Filling machines ( Bottles, Contaniers.)	U	Embouteilleuse	U
Yoğurma makinaları	M	Kneading machines	M	Malaxeurs	M
Ambalaj makinaları	U	Packaging machines	U	Machine d'emballage	U
Şeker kamışı kırıcıları	M	Cane crushers	M	Presse à canne	M
Şeker kamışı kesicileri	M	Cane cutters	M	Découpeuse de canne	M
Şeker kamışı öğütücüleri	H	Cane millis	H	Broyeurs de cannes	H
Şeker pancarı kesicileri	M	Sugar beet cutters	M	Découpeuse de betteraves	M
Şeker pancarı yıkayıcıları	M	Suger beet washers	M	Laveuse à betteraves	M

Pompalar		Pumps		Pompes	
Pistonlu pompalar (Q1 / 100)	H	Piston pumps ( Q1 / 100 )	H	Pompes à piston ( Q1 / 100 )	H
Pistonlu pompalar (Q1 / 100 : 1 / 20)	M	Piston pumps ( Q1 / 100 : 1 / 20 )	M	Pompes à piston ( Q1 / 100 : 1 / 20 )	M
Türbin ( Hafif Akışkan )	U	Turbin ( Light - Liquids )	U	Turbine (Liquides légers)	U
Türbin ( Ağır Akışkan )	M	Turbin ( Semi - Liquids )	M	Turbine (Semi-liquide)	M

Tahrık Makinası Torque Machine Machines couplées	Günlük Çalışma Müddeti (Saat) Daily Working Period (Hour) Utilisation journalière (Heure)	Makinanın Yükleme Karakteristiği Load Characteristics of Machines Caractéristique des charges		
		Hafif Yük U Uniform Load U Charge uniforme U	Orta Yük M Moderate Load M Charge modérée M	Ağır Yük H Heavy Load H Charge élevée H
<b>Elekt. Motorlu</b> / Elect. Motor / Moteurs élect. <b>Türbin</b> / Turbin / Turbine <b>Hidrolik</b> / Hydraulic / Hydraulique	0.....3	0.8	1	1.5
	3....10	1	1.25	1.75
	10...24	1.25	1.5	2
<b>Pistonlu Makinalar ( 4....6 Silindir</b> Piston Machines ( 4....6 Cylinder ) Machine à pistons ( 4.....6 Cylindres )	0.....3	1	1.25	2
	3....10	1.25	1.5	2
	10...24	1.5	1.75	2
<b>Pistonlu Makinalar ( 1....2 Silindir</b> Piston Machines ( 1....2 Cylinder ) Machine à pistons ( 1.....2 Cylindres )	0.....3	1.25	1.5	2
	3....10	1.5	1.75	2.25
	10...24	1.75	2	2.5

Kağıt Endüstri Makinaları		Paper Industry Machines		Industrie Papetière	
Düzeleme silindirleri	H	Glazing Cylinders	H	Cylindres appliniseurs	H
Holender	M	Hollenders	M	Hollenders	M
Kağıt hamur makineleri	H	Pulpers	H	Pulpeuses	H
Kalender	H	Calender	H	Calendrier	H
Taş presler	H	Stone Presses	H	Presse	H
Vakum presler	H	Vacum Presses	H	Presse à aspiration	H
Kuru silindirler	H	Drying Cylinders	H	Cylindres de séchage	H

Taş ve Kil Makinaları		Stone and Clay Working Machines		Roches et Argiles	
Kırıcılar	H	Breakers	H	Broyeurs	H
Döner fırınlar	M	Rotary ovens	M	Four rotatifs	M
Çekiçli değirmenler	H	Hammer mills	H	Broyeux à marteaux	H
Bilyalı değirmenler	H	Ball mills	H	Broyeurs à billes	H
Çarpmalı öğütücüler	H	Beater mills	H	Broyeux à percussions	H
Tuğla presleri	H	Brick presses	H	Presse à pavès	H

Tekstil Makinaları		Textile Machines		Industrie du Textile	
Sargı makineleri ( Q1 / 100 )	M	Batchers ( Q1 / 100 )	M	Machines d'emballages	M
Basma ve boyama mak.	M	Printing and dyeing machines	M	Presse et imprimante	M
Dokuma tezgahları	M	Looms	M	Tisseuse	M

Kompresörler		Compressors		Compresseurs	
Turbo kompresör	M	Turbo compressors	M	Turbocompresseurs	M

Silindirme ve Çekme Tesisleri		Metal Rolling Mills		Aciéries	
Sac kesme makineleri	H	Sheet metal cutting machines	H	Découpeuses	H
Hız ayarlı silindirler	M	Roller adjustment drivers	M	Ajusteuse à presses	M
Çubuk kesme makineleri	H	Billet shears	H	Scies	H
Kabuk sıyırma makineleri	H	Descaling machines	H	Eplucheuse	H
Tel çekme tesisleri	M	Wire drawing machines	M	Enrouleuses	M
Soğuk çekme tesisleri	H	Cooling beds	H	Bande de refroidissements	H
Rulolu nakil ( Hafif )	M	Roller tables ( Lights )	M	Enrouleuses ( légères )	M
Rulolu nakil ( Ağır )	H	Roller tables ( Heavy )	H	Enrouleuses ( lourdes )	H
Silindir haddeleme	H	Manipulators	H	Cylindres	H

Tahrik Makinası Torque Machine Machines couplées	Günlük Çalışma Müddeti (Saat) Daily Working Period (Hour) Utilisation journalière (Heure)	Makinanın Yükleme Karakteristiği Load Characteristics of Machines Caractéristique des charges		
		Hafif Yük U Uniform Load U Charge uniforme U	Orta Yük M Moderate Load M Charge modérée M	Ağır Yük H Heavy Load H Charge élevée H
<b>Elekt. Motorlu</b> / Elect. Motor / <i>Moteurs élect.</i> <b>Türbin</b> / Turbin / <i>Turbine</i> <b>Hidrolik</b> / Hydraulic / <i>Hydraulique</i>	0....3	0.8	1	1.5
	3....10	1	1.25	1.75
	10...24	1.25	1.5	2
<b>Pistonlu Makinalar ( 4....6 Silindir</b> Piston Machines ( 4....6 Cylinder ) <i>Machine à pistons ( 4.....6 Cylindres )</i>	0....3	1	1.25	2
	3....10	1.25	1.5	2
	10...24	1.5	1.75	2
<b>Pistonlu Makinalar ( 1....2 Silindir</b> Piston Machines ( 1....2 Cylinder ) <i>Machine à pistons ( 1.....2 Cylindres )</i>	0....3	1.25	1.5	2
	3....10	1.5	1.75	2.25
	10...24	1.75	2	2.5

**1500 d/d Motorlar / Motors / Moteurs**

Kod	Güç (KW)	Hız (d/d)	Anma Akımı	Moment (Nm)	Verim		IE Sınıfı	Çalışma Sınıfı
					100%	75%		
Code	Power (KW)	Speed (r.p.m.)	Rated Current	Torque (Nm)	Efficiency		IE Class	Duty Type
					100%	75%		
Code	Puissance (kW)	Vitesse (r.p.m.)	Ampère	Couple (Nm)	Efficience		Classe IE	Classe d'utilisation
					100%	75%		
63M4a	0,12	1365	0,41	0,84	57,1	57,1	IE1	S1
63M4b	0,18	1340	0,60	1,28	59,7	59,7	IE1	S1
C63M4	0,25	1350	0,95	1,77	60,7	60,7	IE1	S1
71M4a	0,25	1380	0,81	1,73	61,9	61,8	IE1	S1
71M4b	0,37	1390	1,15	2,54	68,1	68,1	IE1	S1
C71M4	0,55	1385	1,50	3,75	68,6	68,6	IE1	S1
80M4a	0,55	1365	1,60	3,85	69,1	69,0	IE1	S1
80M4b	0,75	1410	2,10	5,08	79,6	79,6	IE2	S1
90S4	1,1	1420	2,60	7,39	82,0	82,0	IE2	S1
90L4	1,5	1430	3,50	10,02	83,0	83,0	IE2	S1
C90L4	2,2	1435	5,00	14,60	84,4	84,5	IE2	S1
100L4a	2,2	1435	5,00	14,60	84,5	84,6	IE2	S1
100L4b	3	1435	6,60	20,00	85,5	85,7	IE2	S1
C100L4	4	1455	8,20	26,30	86,5	86,6	IE2	S1
112M4	4	1455	8,20	26,30	86,7	86,8	IE2	S1
132S4	5,5	1465	11,20	35,90	87,9	88,8	IE2	S1
132M4	7,5	1465	15,40	48,90	89,0	89,1	IE2	S1
C132M4	11	1465	21,00	71,70	89,9	90,0	IE2	S1
160M4	11	1465	21,00	71,70	90,0	90,1	IE2	S1
160L4	15	1465	29,80	97,80	90,6	90,7	IE2	S1
180M4	18,5	1470	34,50	120,00	91,3	91,4	IE2	S1
180L4	22	1470	42,50	143,00	91,7	91,4	IE2	S1
200L4	30	1470	55,00	195,00	92,5	92,6	IE2	S1
225S4	37	1470	67,00	240,00	92,7	92,7	IE2	S1
225M4	45	1470	80,00	292,00	93,3	93,3	IE2	S1
250M4	55	1475	96,00	356,00	93,7	93,8	IE2	S1
280S4	75	1480	133,00	484,00	94,0	94,1	IE2	S1
280M4	90	1480	158,00	581,00	94,3	94,5	IE2	S1
315S4	110	1485	195,00	707,00	94,5	94,5	IE2	S1
315M4	132	1485	230,00	849,00	94,7	94,5	IE2	S1
315M4	160	1485	280,00	1029,00	94,9	94,9	IE2	S1
315L4	185	1485	323,00	1190,00	95,1	95,1	IE2	S1
315L4	200	1485	350,00	1286,00	95,1	95,1	IE2	S1

**1000 d/d Motorlar / Motors / Moteurs**

Kod	Güç (KW)	Hız (d/d)	Anma Akımı	Moment (Nm)	Verim		IE Sınıfı	Çalışma Sınıfı
					100%	75%		
Code	Power (KW)	Speed (r.p.m.)	Rated Current	Torque (Nm)	Efficiency		IE Class	Duty Type
					100%	75%		
Code	Puissance (kW)	Vitesse (r.p.m)	Ampère	Couple (Nm)	Efficience		Classe IE	Classe d'utilisation
					100%	75%		
71M6a	0,18	915	0,61	1,88	63,0	62,9	IE1	S1
71M6b	0,25	915	0,83	2,61	63,8	63,7	IE1	S1
80M6a	0,37	910	1,10	3,88	72,9	72,8	IE1	S1
80M6b	0,55	890	1,50	5,90	70,4	70,3	IE1	S1
90S6	0,75	920	2,00	7,79	75,9	75,9	IE2	S1
90L6	1,1	930	2,90	11,30	78,1	78,1	IE2	S1
100L6	1,5	945	3,60	15,20	79,8	79,7	IE2	S1
112M6	2,2	950	5,40	22,00	81,8	81,7	IE2	S1
132S6	3	960	6,90	29,80	83,3	83,2	IE2	S1
132M6a	4	960	9,00	39,80	84,6	84,5	IE2	S1
132M6b	5,5	960	12,30	54,70	86,0	86,0	IE2	S1
160M6	7,5	960	15,00	74,60	87,2	87,2	IE2	S1
160L6	11	965	22,00	108,90	88,7	88,7	IE2	S1
180L6	15	965	29,00	148,00	89,7	89,7	IE2	S1
200L6a	18,5	975	38,00	182,00	90,4	90,4	IE2	S1
200L6b	22	970	43,00	216,50	91,1	91,1	IE2	S1
225M6	30	980	58,00	292,00	91,7	91,7	IE2	S1
250M6	37	985	69,00	359,00	92,2	92,2	IE2	S1
250S6	45	985	92,00	436,00	92,7	92,7	IE2	S1



Yağ Cinsi Lubricant Art des Lubrifiant	ISO Viskozite sinifi Viscosity class Catégorie de viscosite	DIN 51517-3	Kullanım sicaklığı Usage temperature Gebrauchs temperatur d'usage C°	Firma Firm Marque						
				Mobil	ARAL	bp	Shell	Castrol	KLÜBER LUBRICATION	BELGiN
Mineral Yağ Mineral Oil Huile Minéral	ISO VG 320	CLP	-10.....+90	Mobilgear 600XP320	Degol BG 320	Energol GR-XP 320	OmalaS2 GX 320	Alpha SP 320	Klüberoil GEM 1 N 320	Recompound FL 320
	ISO VG 220	CLP	-10.....+90	Mobilgear 600 XP 220	Degol BG 220	Energol GR-XP 220	OmalaS2 GX 220	Alpha SP 220	Klüberoil GEM 1 N 220	Recompound FL 220
	ISO VG 150	CLP	-10.....+90	Mobilgear 600 XP 150	Degol BG 150	Energol GR-XP 150	OmalaS2 GX 150	Alpha SP 150	Klüberoil GEM 1 N 150	Recompound FL 150
	ISO VG 100	CLP	-15.....+90	Mobilgear 600 XP 100	-	-	OmalaS2 GX 100	Alpha SP 100	Klüberoil GEM 1 N 100	Recompound FL 100
Sentetik Yağ Synthetic Oil Huile Synthétique	ISO VG 320	CLP HC	-30.....+110	Mobil SHC Gear 320	Degol GS 320	Energol SG-XP320	OmalaS4 GX V 320	Optigear Synthetic PD 320 ES	Klübersynth GEM 4N 320	Recompound Syn 320
	ISO VG 220	CLP HC	-35.....+110	Mobil SHC Gear 220	Degol GS 220	Energol SG-XP220	OmalaS4 GX V 220	Optigear Synthetic PD 220 ES	Klübersynth GEM 4N 220	Recompound Syn 220
	ISO VG 150	CLP HC	-40.....+110	Mobil SHC Gear 150	Degol GS 150	Energol SG-XP150	OmalaS4 GX V 150	Optigear Synthetic PD 150 ES	Klübersynth GEM 4N 150	Recompound Syn 150
	ISO VG 100	CLP HC	-45.....+110	Mobil SHC 627	-	-	-	Optigear Synthetic PD 100 ES	Klübersynth GEM 4N 100	Recompound Syn 100

## Redüktörlerin Kontrol ve Bakımları

- Redüktörlerin yağ seviyesi ve miktarını kontrol ediniz. Yağın cinsini İ.MAK kataloğunda yer alan yağ çizelgelerini kullanarak seçiniz.
- Havalandırma tapasının faal olup olmadığına bakınız. Hava tahliye deliği çalışmaz ise redüktör gövdesinin içinde biriken hava, basınç oluşturarak keçelerden yağ sızmasına sebep olur. Böylece yağ azalarak çevre kirliliğine yol açar ve redüktörün verimli çalışmasını engellemiş olur.
- Redüktör bağlantı cıvatalarının gevşeyip gevşemediğini kontrol ediniz, gevşeyen cıvatalar var ise sıkarak suretiyle tedbir alınız. Redüktör montajında meydana gelen eksen kaçıklığında zararlı sarsıntılara dikkat ediniz.
- Redüktörün ilk çalıştırmadan 500 saat sonra, sonraki her 6000 saatte periyodik olarak yağını değiştiriniz.
- Özel hususlar ve çalışma şartları hakkında mutlaka firmamıza danışınız.

## Control and maintenance gearboxes

- Check the oil levels and quantity of your gearboxes. Choose the type and quantity of oil from the İ.MAK catalogue.
- Check if the ventilation stopper is active or not. If the air evacuation hole does not work properly, the accumulated air in the gearbox trunk might causes pressure and gas leakage from the mats.
- Before starting your geared motors, proceed to the checking of connection bolts and screw. Check if they have loosened or not during transport or installation. Take measures by firming loosened bolts. A wrong connexion might create vibration to the axis and conduct to damage of the geared motor.
- Change the oil after 500 hours of initial operation and periodically every 6000 hours of operating the geared motor.
- If you are facing any technical issue, please consult the user guide delivered with the geared motor. In case of special issue or emergency please directly contact your reseller or the closest I-MAK technical center.

## Contrôle et maintenance des réducteurs

- Vérifiez le niveau et la quantité d'huile de façons régulière. Consultez le catalogue I-MAK pour obtenir les niveaux d'huiles requis en fonction du modèle et de la position du réducteur.
- Vérifiez le fonctionnement de la valve d'aération. L'absence d'évacuation de l'air peut provoquer une augmentation de la pression dans le réducteur pouvant conduire à des fuites d'huiles.
- Contrôler les vis et boulons reliant le moteur au réducteur, en cas de mauvaise fermeture le moteur peut créer des vibrations de l'arbre entraînant l'endommagement du motoréducteur.
- La première vidange doit être effectuée après 500 heures d'utilisations du motoréducteur, les vidanges suivantes doivent être effectuées au bout de 6000 heures d'utilisations.
- En cas de problèmes techniques, consultez le manuel d'utilisation fournis à la livraison du motoréducteur. En cas de problèmes particulier ou d'urgence, veuillez à contacter votre revendeur ou le centre technique I-MAK le plus proche.

		<b>YERLİ MALİ BELGESİ</b> Domestic goods certificate <i>Certificat de produit national</i>
		<b>TÜRK STANDARTLARI ENSTİTÜSÜ KRİTERE UYGUNLUK BELGESİ</b> Certificate of conformity to Turkish standards <i>Certificats de conformité aux standards Turcs</i>
		<b>MARKA YENİLEME BELGESİ</b> Certificate of trademark registration <i>Certificat d'enregistrement de marque</i>
		<b>ISO 9001:2008 YÖNETİM SİSTEMİ</b> ISO 9000:2008 Quality management system <i>ISO 9000:2008 : Systèmes de management de la qualité</i>
		<b>ISO10002:2004 MÜŞTERİ MEMNUNİYETİ YÖNETİM SİSTEMİ</b> ISO 10002:2004 Customer satisfaction management system <i>ISO 10002:2004 Management de la qualité - Satisfaction clients</i>
		<b>OHSAS 18001:2007 İŞ SAĞLIĞI VE GÜVENLİĞİ YÖNETİM SİSTEMİ</b> OHSAS 18001:2007 : Occupational health and safety management <i>OHSAS 18001:2007 : Management de la santé et de la sécurité au travail</i>
		<b>AT UYGUNLUK BEYANI</b> CE Declaration of conformity <i>Déclaration de conformité aux standards CE</i>
		<b>EC TYPE EXAMINATION CERTIFICATE</b> ATEX Certificate <i>Certificat ATEX</i>

# ADK Serisi Redüktörler Ölçü Sayfaları

---

Dimensions Pages  
*Dimensions*



**ADK 185-1**

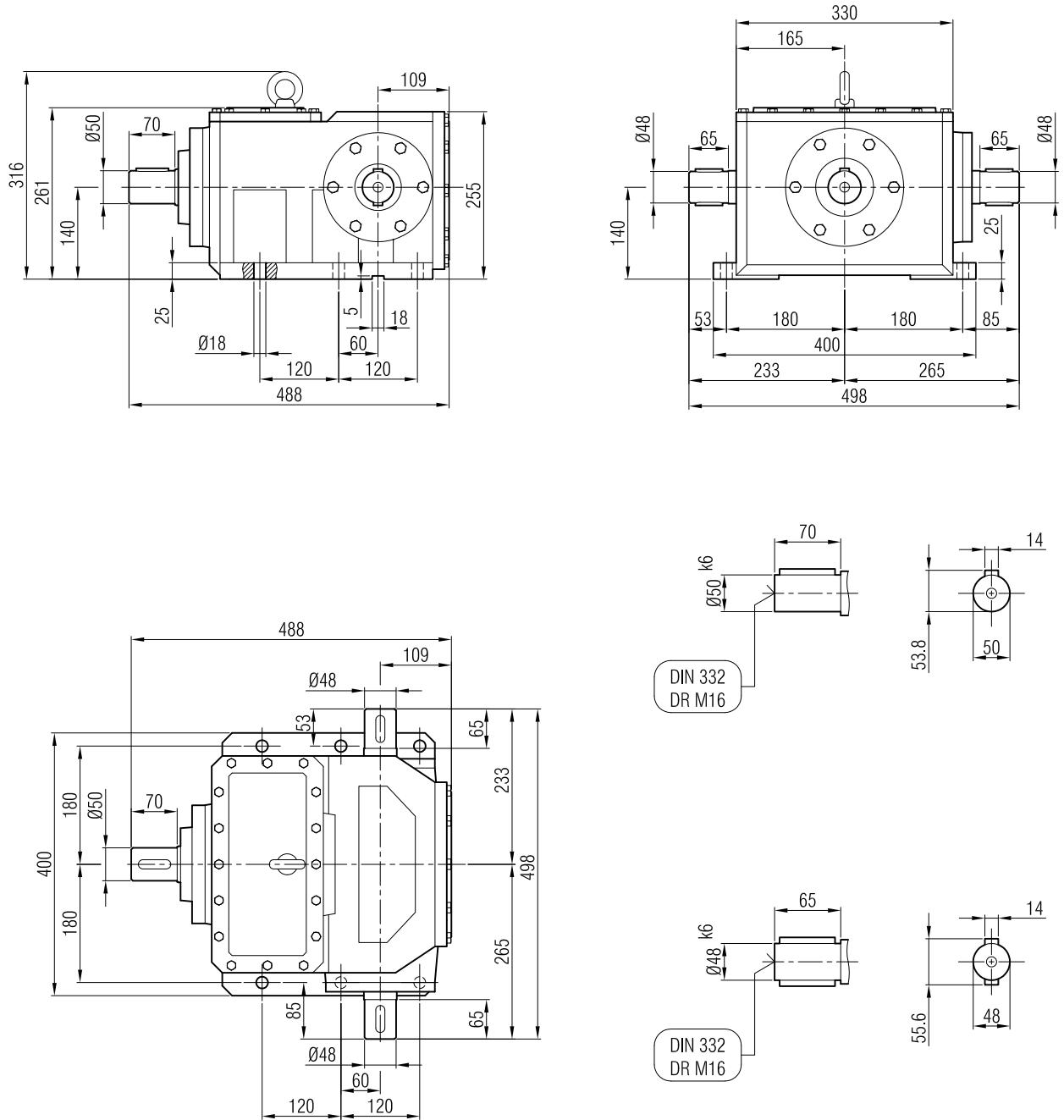



**ADK 185-2**

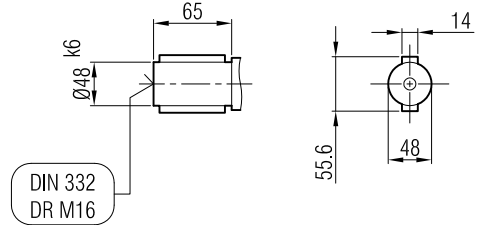
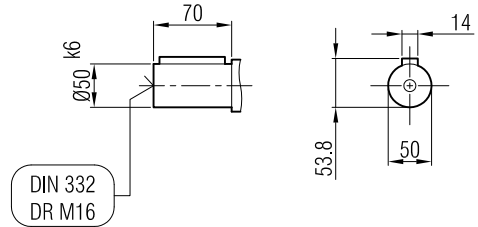
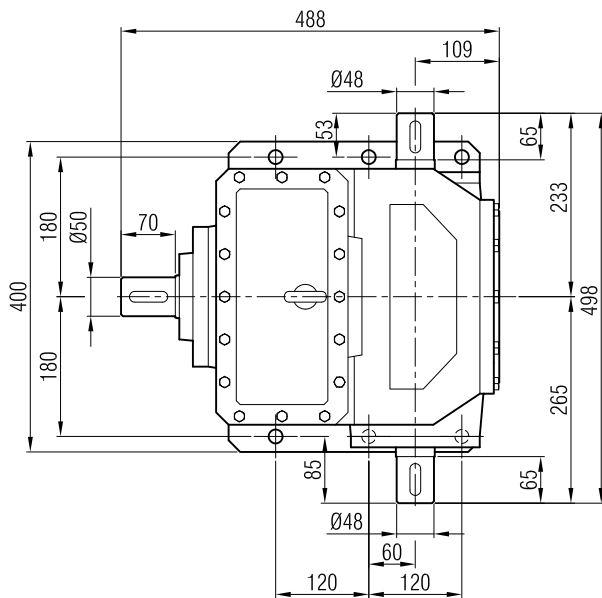
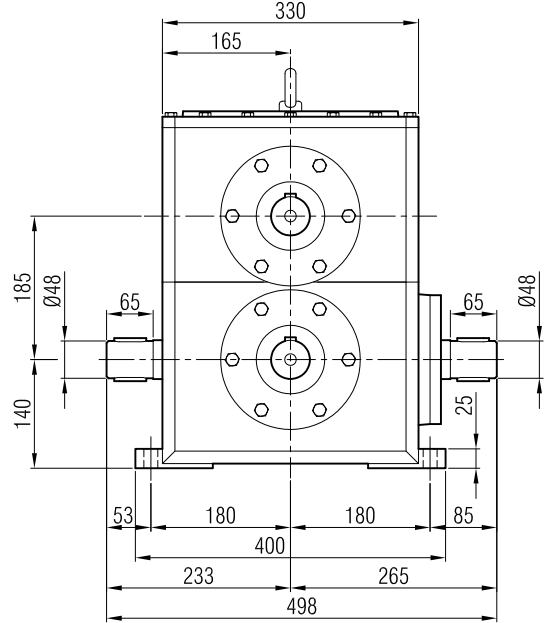
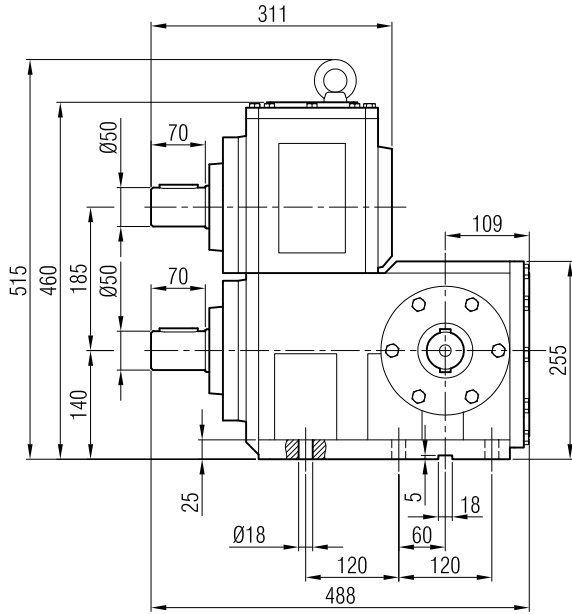

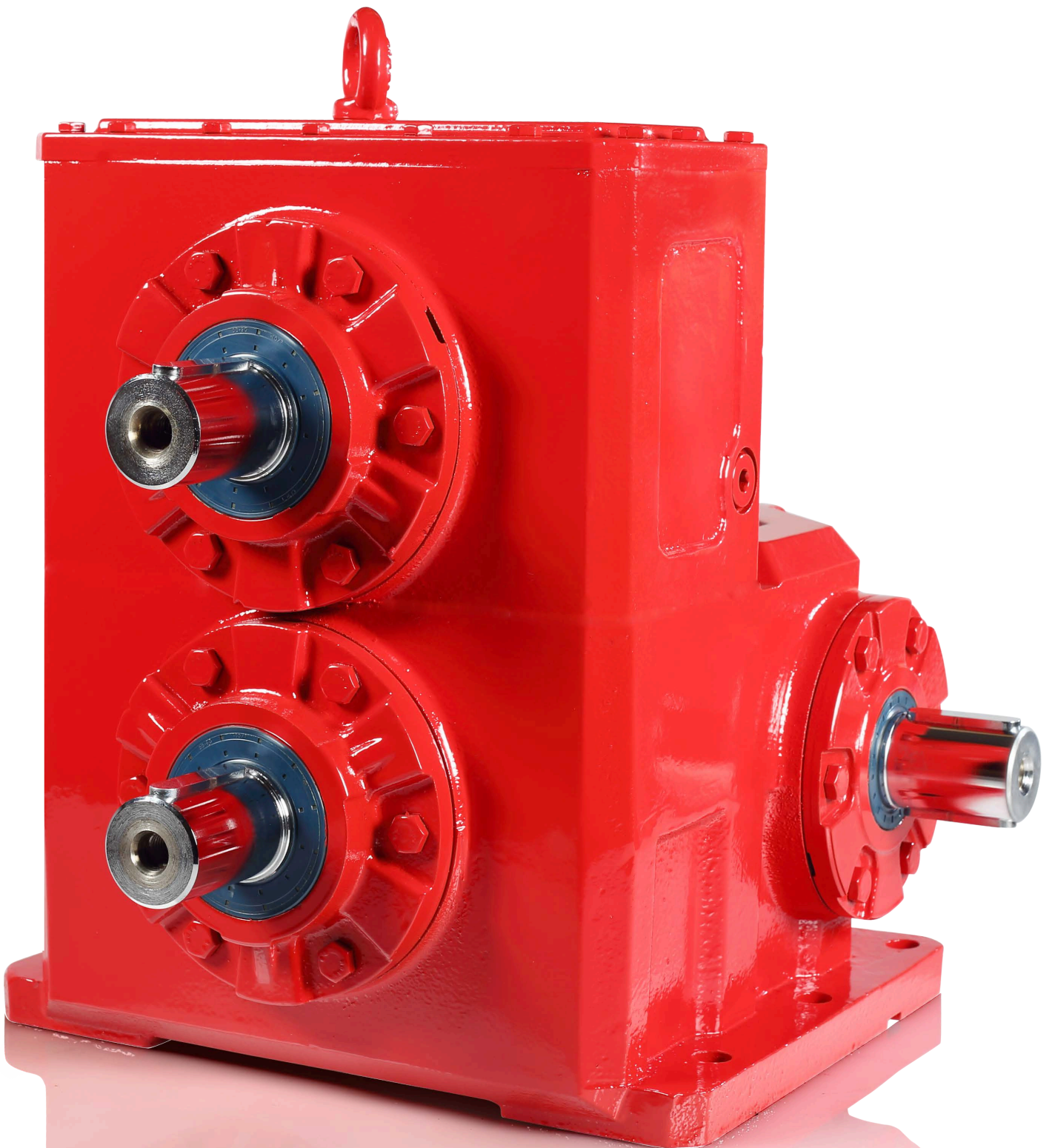

## ADK Serisi Yedek Para Listeleri

---

General Parts List

*Liste des pices dtaches*

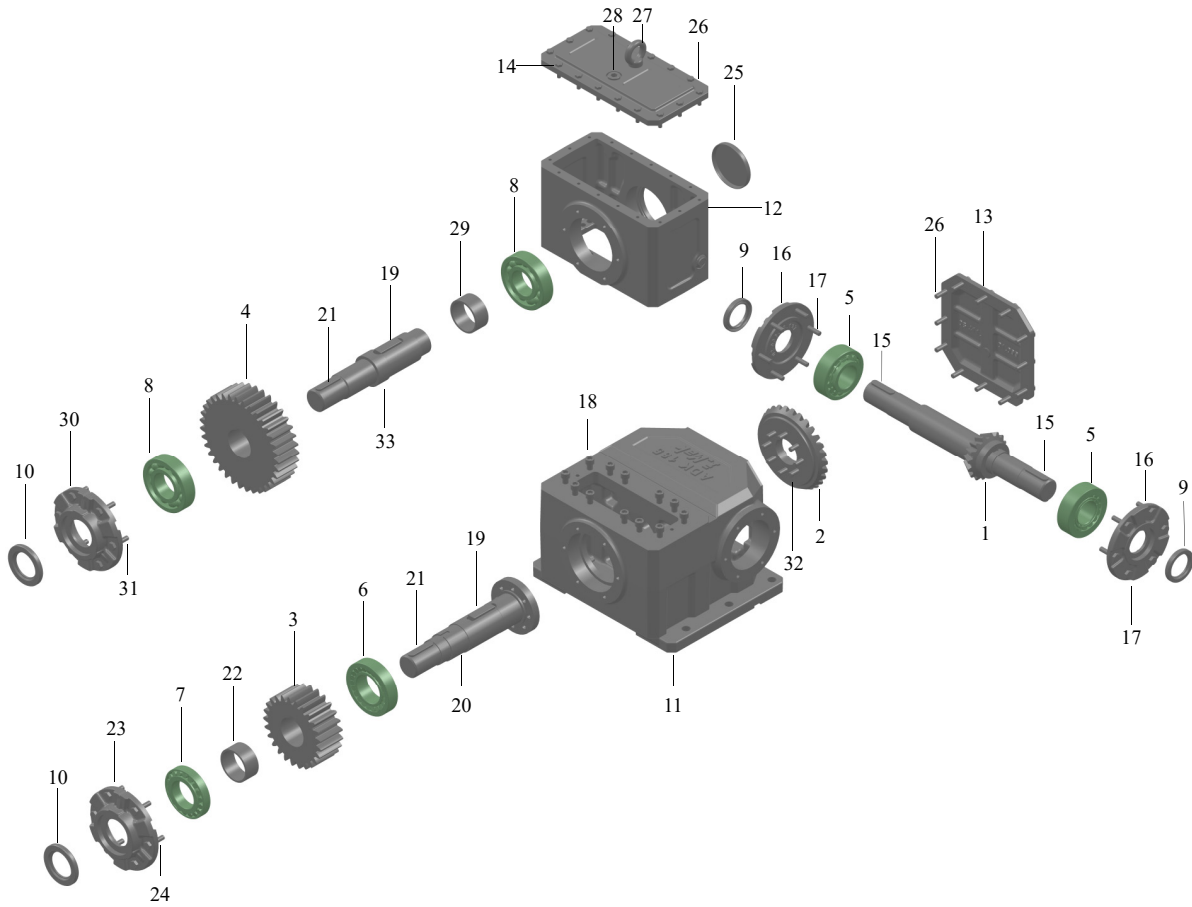

**TİP / TYPE**  
**ADK 185-1 / ADK 185-2**

**TİP / TYPE****ADK 185-1 / ADK 185-2**

1 - Giriş Mili Z1	1 - Input Shaft Z1	1 - Antriebswelle Z1
2 - Ayna Dişlisi Z2	2 - Gear Wheel Z2	2 - Pignon Z2
3 - Dişli Z3	3 - Gear Z3	3 - Pignon Z3
4 - Dişli Z4	4 - Gear Z4	4 - Pignon Z4
5 - Rulman	5 - Bearing	5 - Roulement
6 - Rulman	6 - Bearing	6 - Roulement
7 - Rulman	7 - Bearing	7 - Roulement
8 - Rulman	8 - Bearing	8 - Roulement
9 - Keçe	9 - Seal	9 - Joint
10 - Keçe	10 - Seal	10 - Joint
11 - Alt Gövde	11 - Gear Case (Lower Part)	11 - Carter
12 - Üst Gövde	12 - Gear Case (Upper Part)	12 - Carter
13 - Kapak	13 - Cover	13 - Couvercle
14 - Kapak	14 - Cover	14 - Couvercle
15 - Kama	15 - Key	15 - Clavette
16 - Keçe Kapağı	16 - Seal Cover	16 - Joint
17 - Cıvata	17 - Bolt	17 - Vis
18 - Cıvata	18 - Bolt	18 - Vis
19 - Kama	19 - Key	19 - Clavette
20 - Çıkış Mili	20 - Output Shaft	20 - Arbre de sortie
21 - Kama	21 - Key	21 - Clavette
22 - Burç	22 - Spacer	22 - Anneau d'espacement
23 - Keçe Kapağı	23 - Seal Cover	23 - Joint
24 - Cıvata	24 - Bolt	24 - Vis
25 - Tapa	25 - Locking Cover	25 - Bouchon
26 - Cıvata	26 - Bolt	26 - Vis
27 - Taşıma Kancası	27 - Lifting Eye Bolt	27 - Anneau de levage
28 - Yağ Tapası	28 - Oil Plug	28 - Bouchon d'huile
29 - Burç	29 - Spacer	29 - Anneau d'espacement
30 - Keçe Kapağı	30 - Seal Cover	30 - Joint
31 - Cıvata	31 - Bolt	31 - Vis
32 - Cıvata	32 - Bolt	32 - Vis
33 - Çıkış Mili	33 - Output Shaft	33 - Arbre de sortie



# ADS

SERİSİ / SERIES / SÉRIES



- Monoblok döküm gövdeli
- 3 Farklı gövde büyüklüğü
- 1465 – 2400 Nm moment aralığı
- 1,044 – 1,486 Tahvil aralığı

- Cast iron monobloc housing
- 3 Size of housing
- Torque range from 1465 to 2400 Nm
- Ratio range from 1,044 to 1,486

- *Carter monobloc en fonte*
- *3 tailles de carter*
- *Couple allant de 1465 à 2400 Nm*
- *Rapport de réduction compris entre 1,044 et 1,486*



# ADS Serisi Redüktörler Ölçü Sayfaları

---

Dimensions Pages

*Dimensions*



**ADS 185**

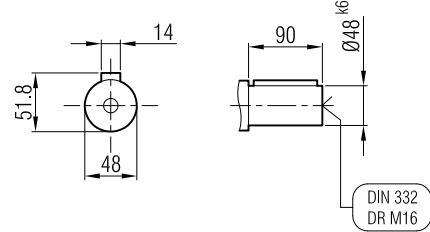
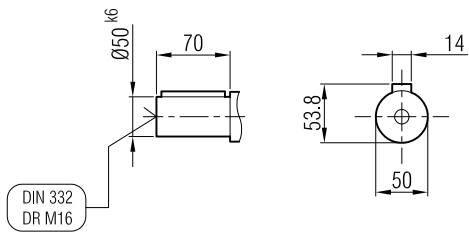
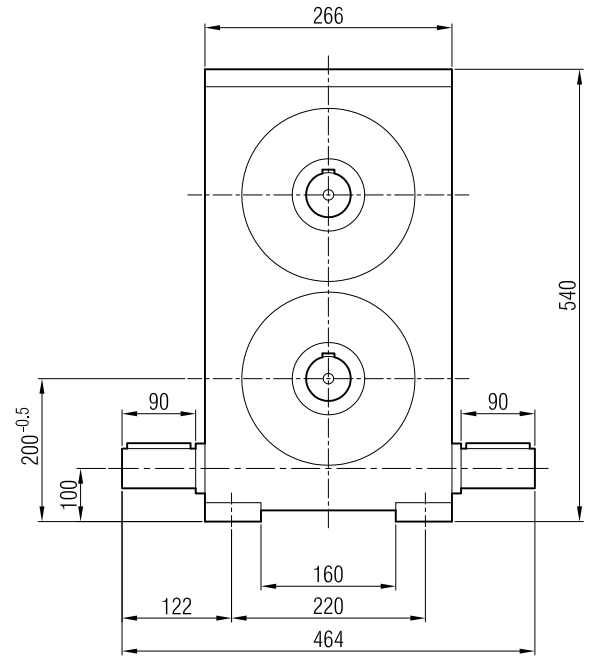
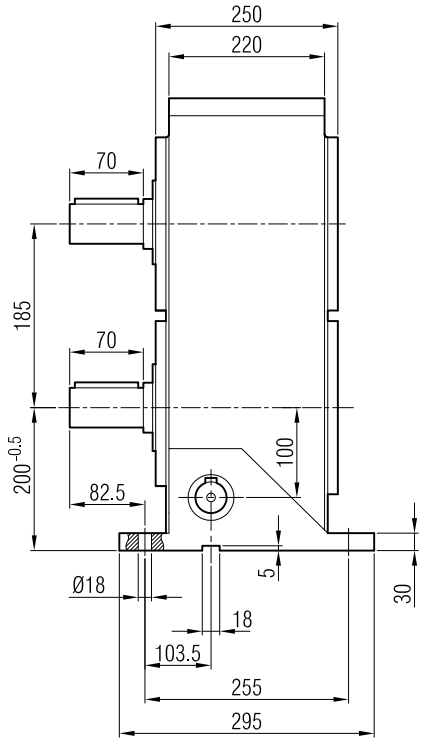



**ADS 230**

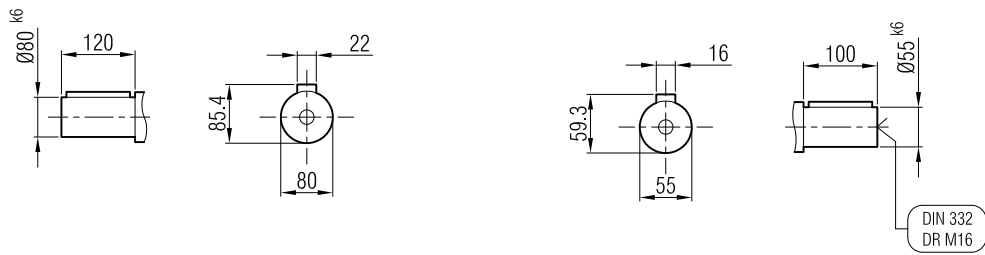
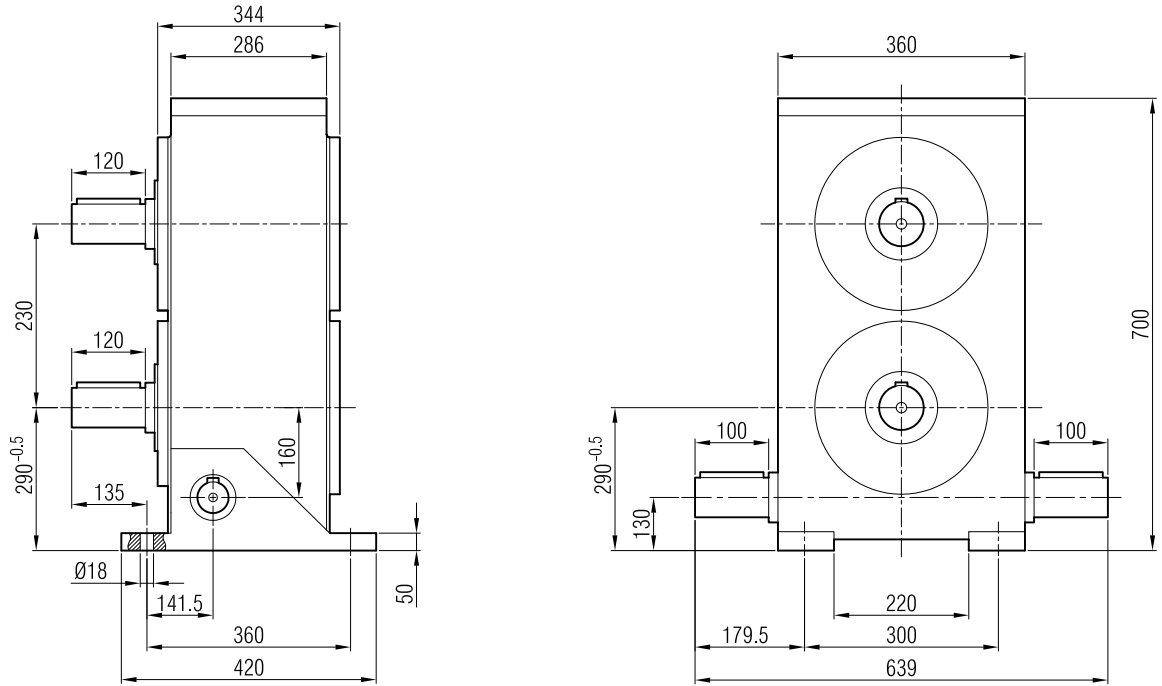





**ADS 290**

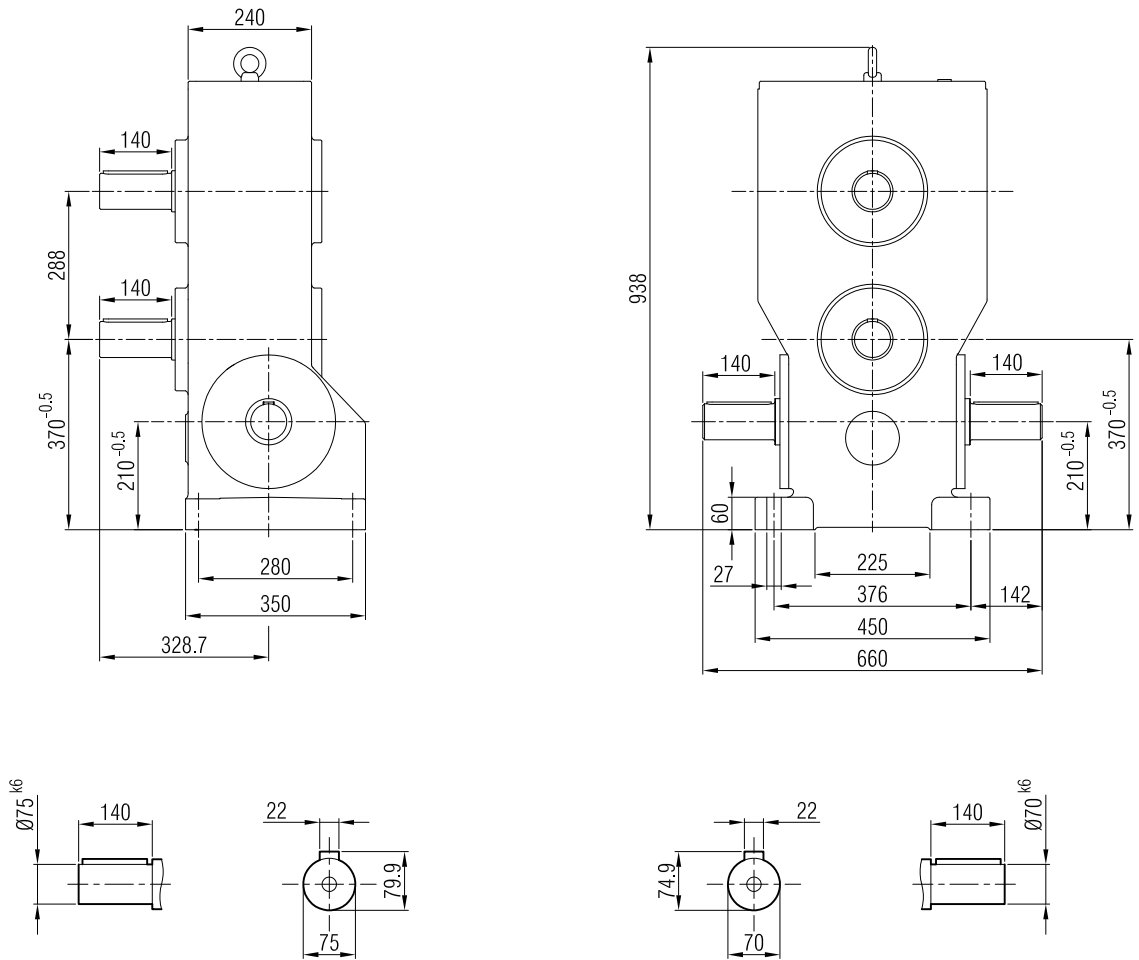

## ADS Serisi Yedek Para Listeleri

---

General Parts List

*Liste des pices dtaches*

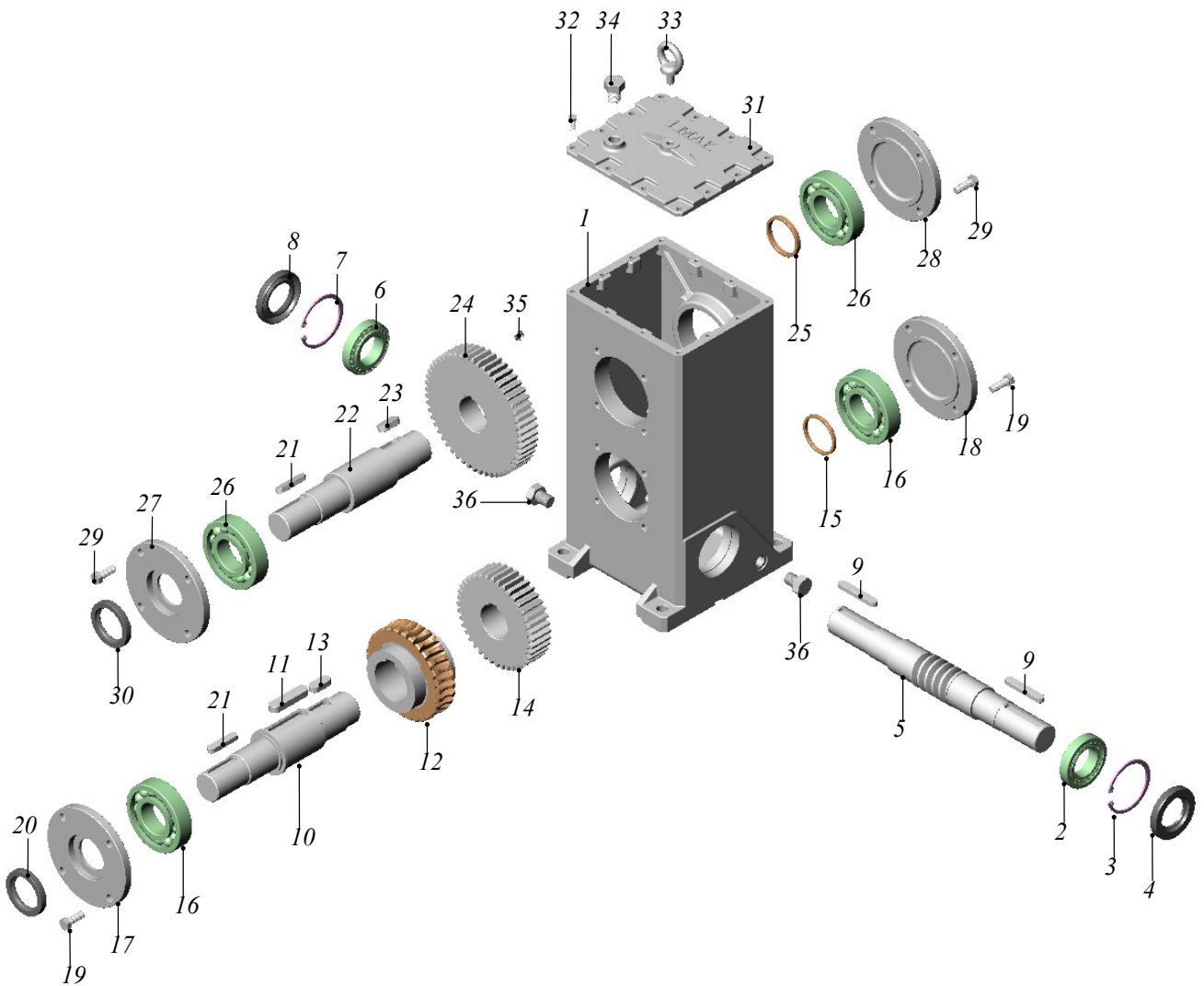
**TİP / TYPE**  
**ADS 185 / 230 / 290**

**TİP / TYPE****ADS 185 / 230 / 290**

1 - Gövde	1 - Gear Case	1 - Carter
2 - Rulman	2 - Bearing	2 - Roulement
3 - Segman	3 - Circlip	3 - Circlip
4 - Keçe	4 - Seal	4 - Joint
5 - Sonsuz Vida (Giriş Milli)	5 - Worm (Input Shaft)	5 - Roulement
6 - Rulman	6 - Bearing	6 - Roulement
7 - Segman	7 - Circlip	7 - Circlip
8 - Keçe	8 - Seal	8 - Joint
9 - Kama	9 - Key	9 - Clavette
10 - Çıkış Mili	10 - Output Shaft	10 - Arbre de sortie
11 - Kama	11 - Key	11 - Clavette
12 - Sonsuz Vida Çarkı	12 - Worm Wheel	12 - Vis sans fin
13 - Kama	13 - Key	13 - Clavette
14 - Dişli Z1	14 - Gear Z1	14 - Pignon Z1
15 - Bilezik	15 - Spacer	15 - Anneau d'espacement
16 - Rulman	16 - Bearing	16 - Roulement
17 - Keçe Kapağı	17 - Seal Cover	17 - Joint
18 - Rulman Baskı Kapağı	18 - Bearing Cover	18 - Roulement
19 - Cıvata	19 - Bolt	19 - Vis
20 - Keçe	20 - Seal	20 - Joint
21 - Kama	21 - Key	21 - Clavette
22 - Çıkış Mili	22 - Output Shaft	22 - Arbre de sortie
23 - Kama	23 - Key	23 - Clavette
24 - Dişli Z2	24 - Gear Z2	24 - Pignon Z2
25 - Bilezik	25 - Spacer	25 - Anneau d'espacement
26 - Rulman	26 - Bearing	26 - Roulement
27 - Keçe Kapağı	27 - Seal Cover	27 - Joint
28 - Rulman Baskı Kapağı	28 - Bearing Cover	28 - Roulement
29 - Cıvata	29 - Bolt	29 - Vis
30 - Keçe	30 - Seal	30 - Joint
31 - Üst Kapak	31 - Upper Cover	31 - Couvercle
32 - Cıvata	32 - Bolt	32 - Vis
33 - Taşıma Kancası	33 - Lifting Eye Bolt	33 - Anneau de levage
34 - Havalandırma Tapası	34 - Vent Plug	34 - Bouchon d'huile
35 - Yağ Seviye Tespit Cıvatası	35 - Oil Level Plug	35 - Bouchon d'huile
36 - Yağ Boşaltma Cıvatası	36 - Drain Plug	36 - Bouchon d'huile

**Notlar**  
Notes

**Notlar**  
Notes



**I-MAK Turkey (Factory-Head Office):**  
Seyhli Mahallesi, Sanayi Caddesi No:1, 34906 Pendik / İstanbul –  
Turkey Tel: +90 216 378 03 26 - Fax: +90 216 378 06 86  
Web: [www.imakreduktor.com](http://www.imakreduktor.com) / E-mail: [imak@imakreduktor.com](mailto:imak@imakreduktor.com)

**I-MAK USA :**  
12610 Galveston Road, Webster, 77598 Texas, USA.  
Tel: 281 480 8711 ext 200 / Fax: 281 480 8656  
E-mail: [sales@sipco-mls.com](mailto:sales@sipco-mls.com)

[www.imakreduktor.com](http://www.imakreduktor.com)

